



0159- Science Radio Science Receiver Standard Formatted Data Unit (SFDU)

Original Release: February 28, 2001

Document Owner:

M. J. Connelly Date 2-9-01
Radio Science System Services Development
Engineer, Antenna, Microwave, and Facilities

Approved by:

J. W. Osman Date 2-9-01
System Services Manager
Antenna, Microwave, and Facilities

Approved by:



W. S. Tai Date 2/20/01
Manager, TMOB Systems Engineering and
Standards Office

Approved by:

J. Stanuk Date 02-05-2001
Interface Engineer and Release Authority

Prepared By:

 2/5/01
A. Jongeling Date
RSR CDE

 2/5/01
S. G. Finley Date
RSR Test Engineer

Reviewed By:

Signature not required

M. Tinto Date
TMOD System Engineering

 02/14/01
V. I. Altunin Date
Telecommunications & Mission Systems Manager

Signature not required

A. L. Berman Date
Telecommunications & Mission Services Manager

Signature not required

A. F. Chang Date
Telecommunications & Mission Services Manager

Signature not required

R. R. Wessen Date
Telecommunications & Mission Services Manager

 2-8-01
P. T. Poon Date
Telecommunications & Mission Systems Manager

Signature not required

J. Wacklery Date
Manager, DSMS Operations Program Office

 2/9/01
S. Tews Date
Telemetry Delivery Subsystem CDE

Signature not required

D. Flora-Adams Date
SYS AMMOS Tables

Signature not required

R. L. Gillette Date
Telecommunications & Mission Services Manager

Signature not required

R. D. Benson Date
Telecommunications & Mission Services Manager

 02/05/01
P. E. Beyer Date
Telecommunications & Mission Systems Manager

 5 Feb 2001
S. W. Asmar Date
Supv., Radio Science Systems Group

 2/7/01
D. P. Holmes Date
Telecommunications & Mission Systems Manager

 2/5/01
B. G. Yetter Date
Telecommunications & Mission Services Manager

 2-5-2001
M. Levesque Date
Service System Development Engineer
Telecommunication Services

 2-6-01
S. Markham Date
GCF Interface Subsystem CDE

Change Log

| Revision | Issue Date | Sections Affected | Change Summary |
|-----------------|-------------------|--------------------------|-----------------------|
| New issue | 02/28/2001 | All | |
| | | | |
| | | | |
| | | | |
| | | | |
| | | | |
| | | | |
| | | | |

This page is intentionally left blank.

Contents

| <u>Section</u> | | <u>Page</u> |
|-------------------|---|-------------|
| 1 | Introduction | 1-1 |
| 1.1 | Purpose and Scope | 1-1 |
| 1.2 | Applicability of this Release | 1-1 |
| 1.3 | Revision and Control | 1-1 |
| 1.4 | Applicable Documents | 1-2 |
| 1.5 | Conventions for Figures | 1-2 |
| 1.6 | Data Item Formats | 1-3 |
| 1.6.1 | Integer | 1-3 |
| 1.6.2 | Unsigned Integer | 1-3 |
| 1.6.3 | Floating Point | 1-3 |
| 1.6.4 | Double Floating Point | 1-3 |
| 1.6.5 | Restricted ASCII | 1-3 |
| 2 | Functional Overview | 2-1 |
| 2.1 | General Information | 2-1 |
| 2.2 | Interface Diagram | 2-1 |
| 2.3 | RSR Signal Path | 2-2 |
| 2.4 | NCO Phase and Frequency | 2-7 |
| 2.5 | RSR Data Time Tags | 2-8 |
| 2.6 | Analyzing RSR Data | 2-8 |
| 2.7 | RSR Data Storage and Delivery | 2-9 |
| 2.8 | Just What is an SFDU Anyway? | 2-9 |
| 2.9 | LVO Structure of the RSR SFDU | 2-10 |
| 3 | Detailed Interface Description | 3-1 |
| 3.1 | RSR SFDU Physical Layout | 3-1 |
| 3.2 | RSR SFDU Label | 3-3 |
| 3.3 | Header Aggregation CHDO Label | 3-5 |
| 3.4 | Primary Header CHDO | 3-6 |
| 3.5 | Secondary Header CHDO | 3-8 |
| 3.6 | Data CHDO | 3-18 |
| Appendix A | | A-1 |
| A.1 | Abbreviations | A-1 |

Figures

| <u>Figure</u> | <u>Page</u> |
|---|--------------------|
| Figure 2-1. RSR to Radio Science user data flow | 2-2 |
| Figure 2-2. Bands, Channels and Sub-channels in the RSR | 2-3 |
| Figure 2-3. Antenna to RSR Signal Path | 2-4 |
| Figure 2-4. Digitizer Signal Path | 2-4 |
| Figure 2-5. Digital Down Converter Signal Path | 2-5 |
| Figure 2-6. VME Data Processor Signal Path | 2-6 |
| Figure 2-7. LVO Structure of the RSR SFDU | 2-11 |
| Figure 3-1. Physical Layout of the RSR SFDU | 3-1 |
| Figure 3-2. RSR SFDU Label | 3-3 |
| Figure 3-3. Header Aggregation CHDO Label | 3-5 |
| Figure 3-4. Primary Header CHDO | 3-6 |
| Figure 3-5. Secondary Header CHDO | 3-11 |
| Figure 3-6. RSR Data CHDO | 3-18 |

Tables

| <u>Table</u> | <u>Page</u> |
|---|--------------------|
| Table 3-1. Supported Sample Rates and Samples Sizes | 3-19 |
| Table 3-2. Sample Packing | 3-20 |

1 Introduction

Section 1
Introduction

1.1 Purpose and Scope

This interface module specifies the format and contents of the Deep Space Mission System (DSMS) Radio Science Receiver (RSR) Standard Formated Data Unit (SFDU). An RSR SFDU, as specified by this module, is a self-identifying, self-delimiting data structure that is used to encapsulate a portion of the radio science data acquired by the RSR. Each SFDU contains data and ancillary information required for post processing. The Radio Science users access the data from the Advanced Multi-Mission Operations System (AMMOS) using a client interface.

While the primary scope of this module is to document the format and contents of the RSR SFDU it also briefly describes the RSR itself and the various mechanisms by which RSR SFDUs are stored and transported.

1.2 Applicability of this Release

This module is the initial release of 820-013, 0159-Science. This module supercedes the interface document 820-13, RSC-11-11B.

1.3 Revision and Control

Revisions or changes to the information herein presented may be initiated according to the procedure specified in the *Introduction* to Document 820-013.

1.4 Applicable Documents

The interface requirements established in this module are derived from guidelines and criteria contained in the following documents and ‘Reference Documents’. Some documents are internal to the DSMS and are included for reference only and do not form a part of this interface.

- | | | |
|------|-----------------------------------|---|
| [1] | TMOD 820-062 | <i>DSMS Terms and Abbreviations</i> DSMS internal document, for reference only. |
| [2] | TMOD 820-013, Module OPS-6-03 | <i>DSMS External Interface Specification—DSN Location Identifiers</i> |
| [3] | TMOD 820-013, Module OPS-6-21A | <i>DSMS External Interface Specification—Standard Code Assignments</i> |
| [4] | TMOD 820-013 Module GCF-10-11 | <i>AMMOS/GCS Data Communications</i> DSMS internal document, for reference only. |
| [5] | TMOD 820-019, Module DFL-1-01 | <i>Interface Design Standards—Network-Level Data Flow Standard</i> DSMS internal document, for reference only. |
| [6] | TMOD 820-019 Module DFL-1-06 | <i>TMOD Fault Tolerant Data Delivery Services Standard</i> DSMS internal document, for reference only. |
| [7] | TMOD 834-070 | <i>Radio Science Receiver Functional Design and Software Requirements Document</i> DSMS internal document, for reference only. |
| [8] | JPL D-5325 | <i>JPL Standard Formatted Data Unit (SFDU) Usage and Description</i> (Issue 5, March 7, 1988) DSMS internal document, for reference only. |
| [9] | CCSDS 620.0-B-2 | <i>CCSDS Recommendation for Space Data System Standards—Standard Formatted Data Units— Structure and Construction Rules</i> (Issue 2, May 1992) |
| [10] | ANSI T-49-12 | <i>ANSI/IEEE STD 754-1985—IEEE Standard for Binary Floating-Point Arithmetic</i> |

1.5 Conventions for Figures

The following conventions are used in figures defining the format of a data record or piece of a data record.

- All byte offsets are assumed to be relative to the beginning of a structure or substructure. The first byte of a structure is called offset 0 (normally shown as the left byte of two); the second byte is at offset 1 (normally shown as the right byte of two), etc.

- If a field in the SFDU requires more than one byte, the most significant byte is at the lowest-number byte offset with each succeeding byte in the next higher byte offset so that the least significant byte is in the highest-number byte offset.

- Bits in a byte are labeled 1 through 8, where the 1st bit (left-most bit) is the most-significant or sign bit and the 8th bit is the least-significant bit (right-most bit). For fields using more than one byte, bits are labeled 1 - n correspondingly.

1.6 Data Item Formats

1.6.1 Integer

An integer format is used to express integral quantities, using two's complement notation. The range for an integer field is $[-1 * (2^n/2)]$ to $[(2^n/2) - 1]$, where n is the number of bits in the field. For example, an 8 bit integer field would have the following range.

$$\text{range} = [-1 * (2^8/2)] \text{ to } [(2^8/2) - 1] = -128 \text{ to } 127.$$

1.6.2 Unsigned Integer

An unsigned integer format is used to express integral quantities using the base 2 number system, also known as binary. The range for an unsigned integer field is 0 to $(2^n - 1)$, where n is the number of bits in the field.

1.6.3 Floating Point

Floating point numbers are represented in the basic single format defined in document ANSI/IEEE Std 754-1985. This representation is commonly referred to as the 32-bit IEEE floating point format.

1.6.4 Double Floating Point

Double floating point numbers are represented in the basic double format defined in document ANSI/IEEE Std 754-1985. This representation is commonly referred to as the 64-bit IEEE floating point format.

1.6.5 Restricted ASCII

Restricted ASCII is a subset of the ASCII character set consisting of uppercase letters A to Z and digits 0 to 9.

This page intentionally left blank

2 Functional Overview

Section 2
Functional Overview

2.1 General Information

The RSR is a computer controlled open loop receiver that digitally records a spacecraft signal through the use of an analog to digital converter (ADC) and up to four digital filter sub-channels. The digital samples from each sub-channel are stored to disk in one second records in real time. In near real time the one second records are partitioned and formatted into a sequence of RSR SFDUs which are transmitted to JPL's Advanced Multi-Mission Operations System (AMMOS). Included in each RSR SFDU is the ancillary data necessary to reconstruct the signal represented by the recorded data samples in that SFDU. Analysis of variations in the amplitude, phase, and frequency of the recorded signals provides information on the ring structure, atmospheric density, magnetic field, and charged-particle environment of planets which occult the spacecraft. Variations in the recorded signal can also be used for gravity wave detection.

2.2 Interface Diagram

The functional data flow, as depicted in Figure 2-1, operates using a DSMS internal Fault Tolerant Data Delivery (FTDD) service starting from the RSR and ending with a TDS client receiving the data at the Radio Science host computer. Both sides of the interface utilize DSMS common software.

Application programs will link with common services communications software. This software provides the facilities, transparent to the application program, for the transporting of the data. The functional flow consists of

- (1) RSR publishing the RSR SFDUs as stream data, using Fault Tolerant Data Delivery (FTDD) services.
- (2) The Reliable Network Service (RNS) delivering the data to its subscriber, the GCF Interface (GIF).
- (3) The GIF sending the SFDUs to the Telemetry Delivery Subsystem (TDS), which spools the data for real-time delivery or archival. This segment of the data flow uses the communication services of the Data Transport Subsystem (DTS).
- (4) The Radio Science user (or project) using its TDS-provided client to access the collected data. The TDS client must run on UNIX-based hosts.

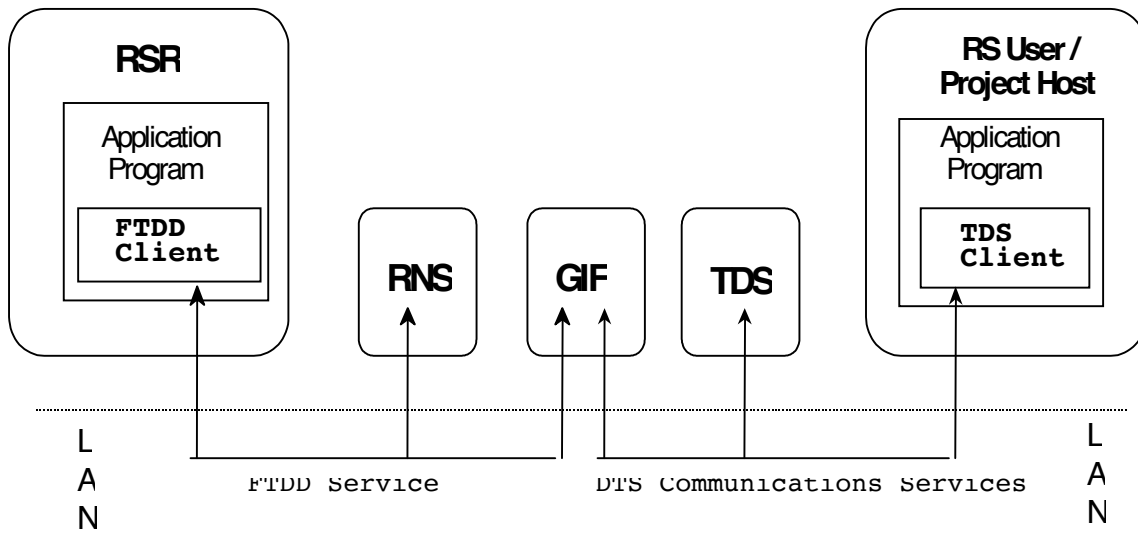

Figure 2-1. RSR to Radio Science user data flow

2.3 RSR Signal Path

The diagram in Figure 2-2 shows the relationship between the subchannels, channels and bands that are supported by the RSR and described in more detail in this section.

A spacecraft transmits a signal at RF, S_Band, X_Band, or Ka_band, to a receiving antenna on earth. Once received the RF signal is down converted to an IF signal of about 300 MHz and then fed via an IF distribution network into one input of the IF Selector Switch (IFS). The IFS is a full cross-bar switch which allows each RSR to select from any of the IF signals feeding the IFS inputs. Each output of the IFS feeds an IF signal into one input of the RSR Digitizer (DIG). Figure 2-3 illustrates the signal path from the antenna to the RSR and the signal path within the RSR.

Figure 2-4 illustrates the signal path through the DIG. In the DIG, the IF signal first passes through a programmable attenuator which is automatically adjusted at the start of each pass to provide the proper signal level at the ADC. Next, the signal passes through a Band Pass Filter (BPF) which selects a frequency band from 265 to 375 MHz. The filtered signal is then down converted by a 256 MHz LO and low pass filtered (LPF) before being sampled by the ADC. The ADC converts the signal into a 256 Msample/sec stream of 8-bit digital data which is fed into the Digital Down Converter (DDC). The DIG also provides a 1 Pulse Per Second (1PPS) signal and a 256 MHz data clock. The 1PPS signal marks the digital sample taken at the start of each second.

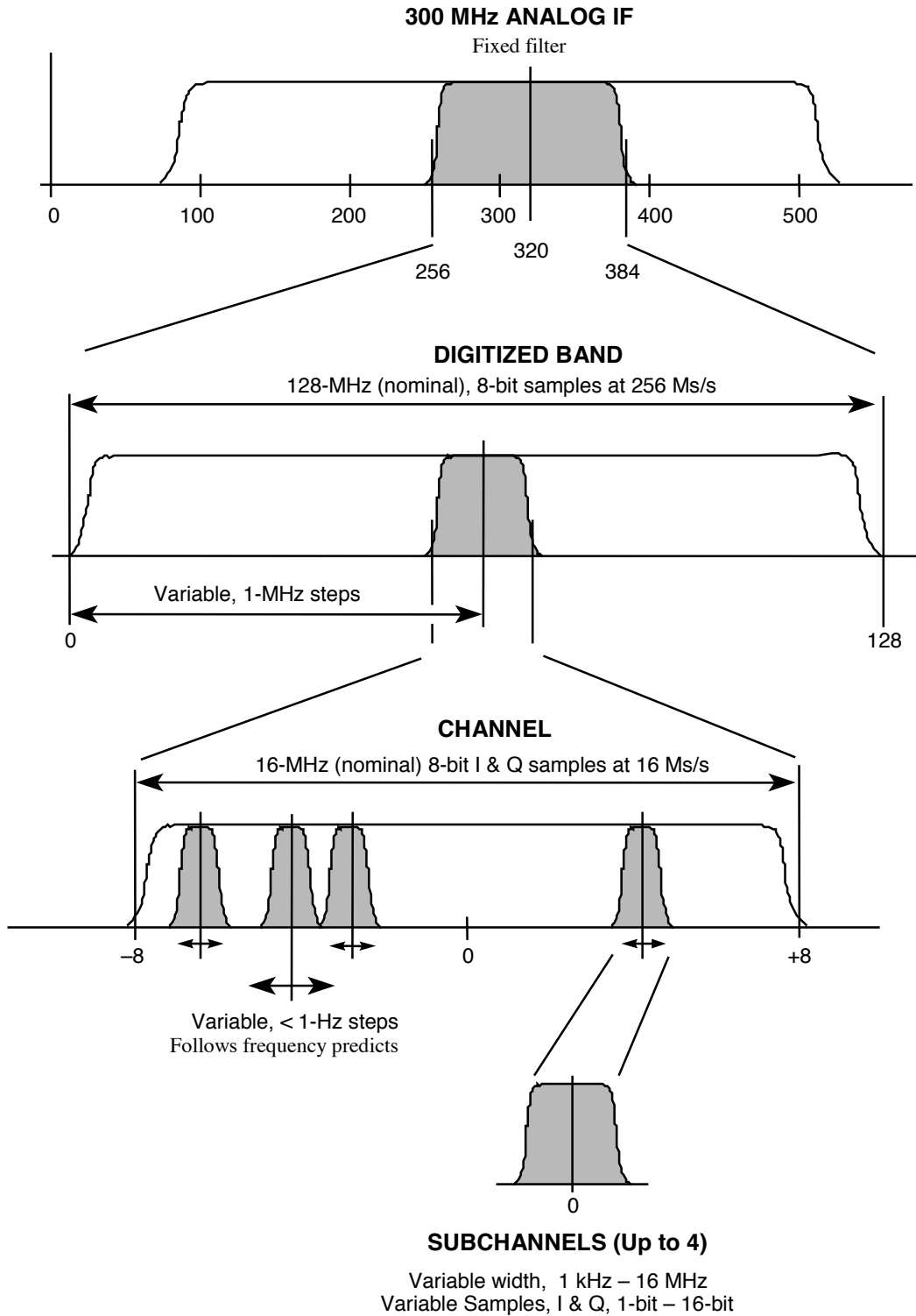

Figure 2-2. Bands, Channels and Sub-channels in the RSR

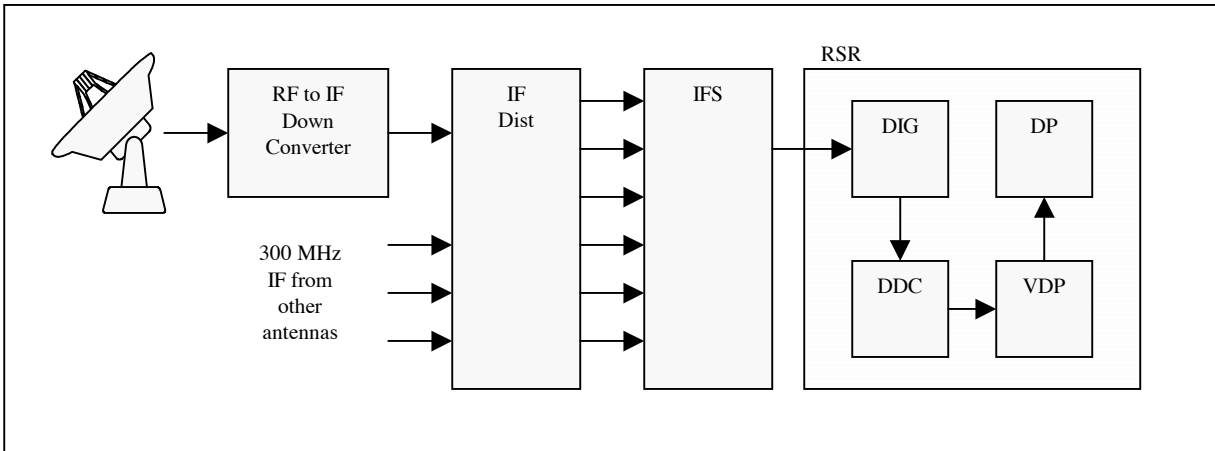

Figure 2-3. Antenna to RSR Signal Path

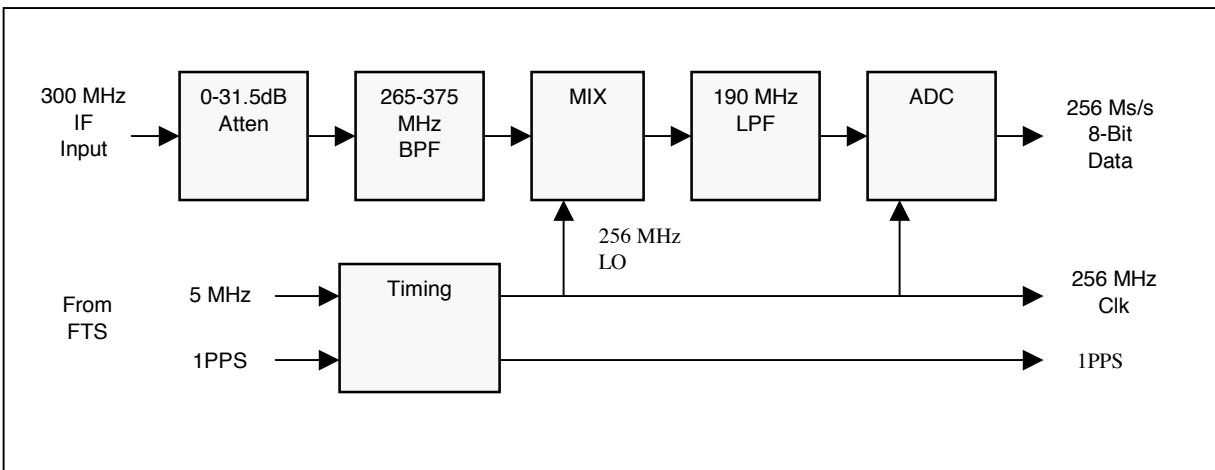

Figure 2-4. Digitizer Signal Path

Figure 2-5 illustrates the signal path through the Digital Down Converter (DDC). The function of the DDC is to select a 16MHz channel from the frequency band digitized by the DIG. This is accomplished through the use of Finite Impulse Response (FIR) filters with revolving banks of filter coefficients. The data stream from the DIG is separated into eight decimated data streams. These streams are fed into two sets of FIR filters, one set produces In-phase (I) data while the other produces Quadrature-phase (Q) data. This arrangement acts as a digital filter, down converter and decimator. The position of the selected 16MHz channel can be adjusted in 1MHz steps, it is usually set so that the spacecraft signal is centered in the pass band of the channel filter. The output of the DDC is a 16 Msample/sec complex digital data stream with a bandwidth between -8 MHz and $+8$ MHz. Each of the complex samples contains 8-bit I and Q components. The timing circuits in the DDC convert the 256

MHz clock and 1PPS signals supplied by the DIG into a msec time code. The msec time code marks the msec samples and identifies the msec of the second to which they correspond. The 16 Msample/sec data stream and the msec time code are fed to the VME Data Processor (VDP) for further processing.

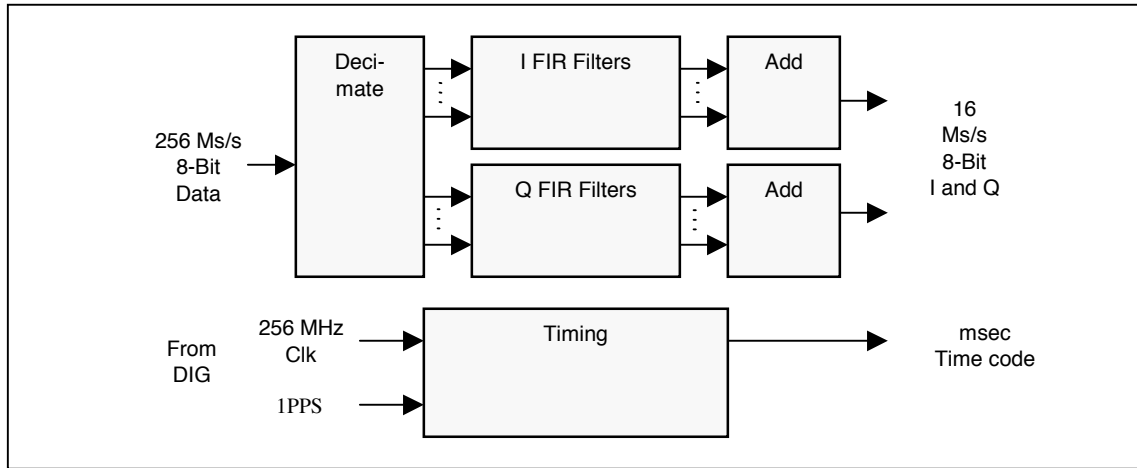

Figure 2-5. Digital Down Converter Signal Path

The VDP contains a real-time control computer (RT) and a set of custom boards to perform the necessary digital signal processing (DSP). The custom boards are controlled by the RT, which in turn is controlled via a point-to-point network connection by a Unix workstation known as the Data Processor (DP). The VDP receives the 16 Msample/sec complex data stream and msec time code from the DDC. The data stream is split into four identical copies, each copy feeding a separate VDP sub-channel. The msec time code is converted into a msec interrupt used to drive the real time software running on the RT.

As depicted in Figure 2-6, each VDP sub-channel is composed of a numerically controlled oscillator (NCO), a complex multiplier, a decimating FIR filter, and a data packer. These components function together to isolate and record a desired portion of the 16MHz channel. The 16 Msample/sec data stream is fed into the complex multiplier where it is multiplied by the signal generated by the NCO. The phase and frequency of the NCO signal are updated at each millisecond by the RT and are selected so that the center frequency of the desired portion of the 16 MHz channel is down converted to zero Hz. The RT uses polynomials derived from frequency predicts to compute the desired phase and frequency of the NCO signal. More details regarding the phase and frequency of the NCO signal are provided in Section 2.4.

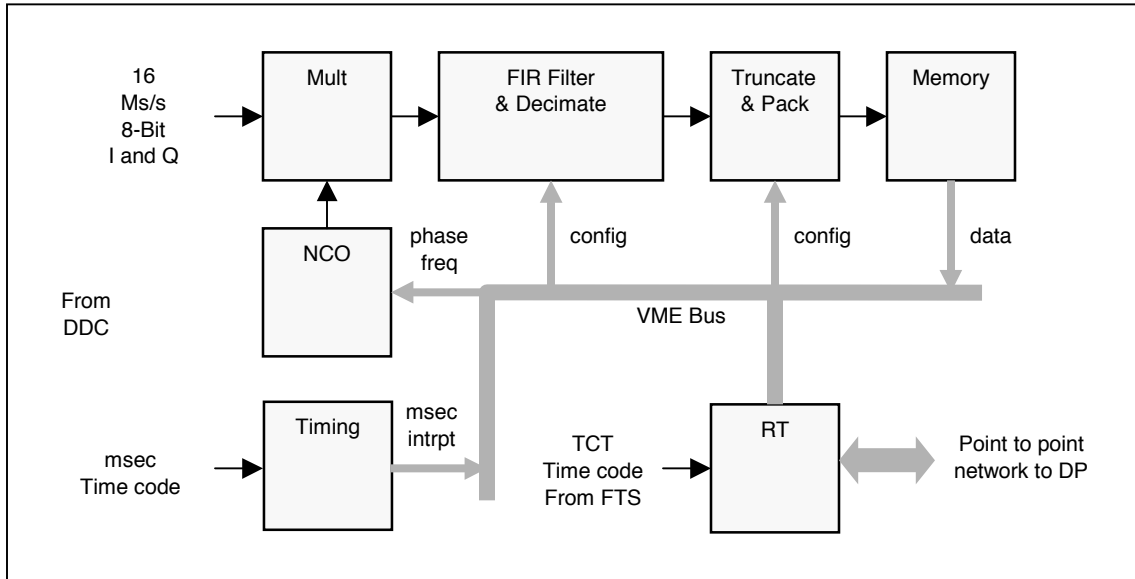

Figure 2-6. VME Data Processor Signal Path

After down conversion in the complex multiplier, the data stream is fed into the decimating FIR filter where its bandwidth and sample rate are reduced. The output bandwidth and sample rate of the decimating FIR filter is adjustable from 1 KHz to 16 MHz. Valid selections are listed in Table 3-1. The decimating FIR filter also provides for adjustment to the sub-channel gain. This gain adjustment is necessary to take full advantage of the dynamic range in the hardware. For example, a signal which is dominated by noise and reduced to a 1KHz bandwidth will require more gain than a signal that is dominated by a spacecraft carrier. The RSR software automatically sets the sub-channel gain at the start of each pass based on the filter bandwidth and the expected signal-to-noise ratio of the signal.

The next step of the signal processing reduces the sample size of the filtered data. As the digital data flows through the various DSP circuits in the VDP sub-channel the number of bits in a data sample is increased. This is necessary in order to maintain precision in the various operations performed on the data. When the DSP operations are complete, the sample size of the data can be reduced to the desired number of bits per output sample. The size of the output samples is adjustable: 1, 2, 4, 8, and 16 bit samples are supported. The reduction in sample size is accomplished through truncation. For example, if the sub channel is configured to produce 8-bit samples the upper most 8-bits of the digital data produced by the FIR filter are taken as the sample, while the remaining lower order bits are discarded. This truncation creates an offset of -0.5 in the output data stream which must be corrected in post processing software. This is easily accomplished by adding 0.5 to each data sample.

After the samples have been truncated to the correct size they are packed together to form 32-bit data words. The most significant 16 bits are packed with quadrature (Q) data and the least significant 16 bits are packed with in-phase (I) data. Between 1 to 16 samples are packed into each 32-bit data word depending on how many bits per sample are used. When the data packer finishes filling a 32-bit data word with samples, it stores the data word in a memory buffer and starts filling a new data word. Each millisecond the RT reads the data words from the sub-channel memory buffers and moves them into

one second data buffers stored in the RT's on board memory. At the end of each second the RT sends the one second data buffers collected from each sub-channel to the DP on a point to point 100 Mbit ethernet connection. Each one second data buffer sent to the DP also contains ancillary information needed to analyze the data in the buffer. On the DP the one second data buffers are analyzed to provide monitor data and spectrum plots. If recording is enabled they are stored as one second records in a DP data file.

2.4 NCO Phase and Frequency

At the start of each pass the RSR is provided with a file containing a list of frequency predicts points. Using the predicts points the RT computes the expected sky frequency of the spacecraft signal at the beginning, middle and end of each second. From the sky frequency points and the values of the RF to IF LO, the DDC LO, and the current values of the Frequency Offset (FRO), Subchannel Frequency Offset (SFRO) and Frequency Rate (FRR) parameters, the RT computes the expected frequency of the spacecraft signal within the DDC channel. Using the three DDC channel frequency points, the RSR computes the coefficients of a frequency polynomial. The frequency polynomial spans a one second interval and is fitted to the predicted DDC channel frequency points. Next the RT computes the coefficients of a phase polynomial. The phase polynomial also spans a one second interval and is computed by integrating the frequency polynomial. The end value of one phase polynomial is used as the start phase of the next phase polynomial so that the modeled phase across second boundaries is continuous. The RT computes the phase and frequency polynomials in real time. Over the course of each second, it computes the polynomials to be used for the next second.

As mentioned earlier the phase and frequency of the VDP sub-channel NCOs are updated each msec using values computed from phase and frequency polynomials. Each msec the RT receives an interrupt from one of the VDP sub-channels. In response to this interrupt the RT reads a register in the VDP sub-channel which indicates the current msec of the second. The VDP sub-channel obtains this information from the msec time code that accompanies the data it is processing. Using the msec information and the phase and frequency polynomials, the RT computes the phase and frequency that the sub-channel should use at the start of the next msec. The RT writes the new phase and frequency to holding registers in the sub-channel NCO. At the start of the next msec the NCO moves the new phase and frequency from the holding registers into active registers and begins using them.

To obtain the desired NCO phase for each msec, the RT evaluates the phase polynomial at the start of the msec as indicated in the following equation. It should be noted that the *msec* parameter has a range of from 0 to 999.

$$\begin{aligned} \text{Phase}(msec) = & \text{Phase_Coef_1} + \\ & \text{Phase_Coef_2} * (msec / 1000) + \\ & \text{Phase_Coef_3} * (msec / 1000)^2 + \\ & \text{Phase_Coef_4} * (msec / 1000)^3 \end{aligned}$$

To obtain the desired NCO frequency for each msec the RT evaluates the frequency polynomial at the middle of the msec as indicated in the following equation.

$$\begin{aligned} \mathit{Freq}(\mathit{msec}) = & \mathit{Freq_Coef_1} + \\ & \mathit{Freq_Coef_2} * ((\mathit{msec} + 0.5) / 1000) + \\ & \mathit{Freq_Coef_3} * ((\mathit{msec} + 0.5) / 1000)^2 \end{aligned}$$

The coefficients of the phase and frequency polynomials used in these equations are stored in the ancillary data of each SFDU.

2.5 RSR Data Time Tags

Each SFDU generated by the RSR contains sub-channel sample data and sub-channel NCO phase and frequency polynomials which require time tags. The RSR hardware and software have been designed to compensate for pipeline delays in the signal processing path that would cause offsets between the data time tags and the polynomial timetags. The DDC compensates for the pipeline delay associated with its signal processing by adjusting the msec time code that it generates. The VDP sub-channel partially compensates for the delay associated with its signal processing by delaying the start time of the FIR filter so that the total delay is in multiples of an output sample. The RT completes the VDP sub-channel compensation by copying data read from the sub-channel into the correct place in its one second data buffers.

The time tag of the first data sample in an SFDU is obtained from the “year”, “day of year”, and “second of day” fields of the SFDU time tag. It indicates the time at which the sample was created by the DIG ADC. Time tags for subsequent samples in the SFDU should be obtained by incrementing the time tag with the sample period of the data. RSR time tags are accurate to the 100 nano-sec level.

The NCO phase and frequency polynomials span one second intervals which begin and end on the second. The polynomial coefficients are copied into the ancillary information of each SFDU when the one second data buffers from the RSR RT are partitioned into multiple SFDUs. For a given SFDU the time tag of the one second interval over which the polynomials apply is specified by the “day counter” and “second counter” fields of the SFDU time tag.

2.6 Analyzing RSR Data

The previous sections of this document described how RSR SFDUs are created, this section will describe how to use the information they contain. The “RF frequency” or “Sky frequency” is a characteristic of the recorded signal that is of primary interest. An equation for obtaining the Sky frequency from the information contained in the SFDU is given below.

$$\mathit{Sky\ Freq} = \mathit{RF_to_IF_LO} + \mathit{DDC_LO} - \mathit{NCO_Freq} + \mathit{Resid_Freq}$$

RF_to_IF_LO is the amount of down conversion applied to the signal in the RF to IF down converter. This information is stored in the secondary header of the RSR SFDU, its value depends on the RF band of the spacecraft signal, S_Band, X_Band, or Ka_band. It is constant for a data set.

DDC_LO is the total amount of down conversion applied to the signal in the DIG and DDC. This information is stored in the secondary header of the RSR SFDU, its value depends on the position the of the spacecraft signal in the IF frequency band. It is usually constant for a data set, but its value can be changed during a pass with the DDCLO command

NCO_Freq is the frequency of the signal generated by the VDP sub-channel NCO. As described in section 2.2 the NCO signal is used in conjunction with a complex multiplier to down convert the spacecraft signal to zero Hz. The phase and frequency of the NCO signal are updated each msec based on polynomials derived from frequency predicts. The coefficients of these polynomials are stored in the secondary header of the RSR SFDU. Refer to section 2.4 for details regarding the use of these polynomials.

Resid_Freq is the residual frequency of the recorded data. The RSR is driven by frequency predicts which are designed to track a spacecraft signal as it moves in frequency. The frequency predicts usually contain errors which cause the recorded signal to have a residual frequency. To obtain the residual frequency post processing software must perform spectral analysis of the recorded data.

2.7 RSR Data Storage and Delivery

The digital samples from each RSR sub-channel are stored to disk in one second records in real time. In near real time the one second records are partitioned and formatted into a sequence of RSR SFDUs which are transmitted to JPL's Advanced Multi-Mission Operations System (AMMOS). The number of SFDUs per one second data record depends on the bandwidth and sample size of the recorded data. Table 3-1 contains a list of valid configurations.

The RSR delivers the RSR SFDUs to AMMOS via the Fault Tolerant Data Delivery (FTDD) interface of the Reliable Network Server (RNS). In accordance with references {4} and [5]. Each RSR SFDU is encapsulated in a Standard DSN Block (SDB). For details regarding the FTDD interface refer to reference document [6].

2.8 Just What is an SFDU Anyway?

The SFDU is an international structure standard for data products. This standard was developed to facilitate the transfer of spacecraft data between organizations that use different computer systems and to ensure that data can be preserved effectively for future use. The JPL SFDU structure and construction rules are based on guidelines for SFDU structure provided by the Consultative Committee

for Space Data Systems (CCSDS). Within these guidelines, JPL has devised its own standards for the structure and construction of SFDUs used within JPL.

Any SFDU is composed of Label-Value Objects (LVOs). An LVO is a data structure that is composed of a fixed length label field and a variable length value field. The label field provides for the data structure to be self-identifying and self-delimiting. The value field contains either more LVOs or user-defined data. An LVO with a value field containing purely user-defined data is referred to as a simple LVO. An LVO with a value field containing a sequence of one or more LVOs is referred to as a compound LVO.

The label field of an LVO is divided into type attribute and length attribute subfields. The type attribute subfield(s) of the LVO label provides the self-identifying property of the LVO. Within the application domain, the type attribute is a unique reference to a description of the format and interpretation of the data contained in the value field of the LVO. For JPL SFDUs, type attributes are assigned by the NASA JPL Control Authority, which is also responsible for maintaining the associated data descriptions. The CCSDS maintains a registry of control authorities.

The length attribute subfield(s) of the LVO label provides the self-delimiting property of the LVO. The length attribute subfield contains the length, in bytes, of the value field of the LVO. While all of the LVOs described in this module make use of length attribute subfields it should be noted that other means are available to enable an LVO to be self-delimiting.

Label-Value Objects used to construct CCSDS SFDUs must follow specific CCSDS structuring and labeling recommendations. In particular they must contain a standard 20-byte LVO label that conforms to strict format requirements. In some situations the standard 20-byte CCSDS LVO label incurs too much overhead to be used practically. To deal with this problem JPL has defined a short, 4-byte label that can be used in the same manner as the longer CCSDS label. An LVO constructed with this type of label is termed a Compressed Header Data Object (CHDO), usually pronounced "chay-doe." The CHDO label contains a two-byte type field and a two-byte length field. CHDOs are used when concerns for efficiency rule out the use of full CCSDS labels. Although the CHDO structure itself is used for exchange within JPL subsystems, CHDOs must be enclosed within legal CCSDS SFDU labels in order to be readable by other systems that use the SFDU standard.

2.9 LVO Structure of the RSR SFDU

An RSR SFDU is a compound LVO that conforms to the JPL SFDU structure and construction rules specified in reference [8]. At the top level it is composed of an SFDU label field and a value field. The value field of the RSR SFDU contains two LVOs, a header aggregation CHDO and a data CHDO. The header aggregation CHDO is a compound LVO; its value field contains two simple LVOs, a primary header CHDO and a secondary header CHDO. The header aggregation CHDO exists solely for the purpose of allowing the primary and secondary header CHDOs to be grouped together and treated as a single object. The value fields of the primary and secondary header CHDOs contain ancillary data (identification, configuration, predicts models, etc.) that pertain to the information in the data CHDO. The data CHDO is a simple LVO; its value field contains the data samples recorded by the RSR. Figure 2-7 depicts the LVO structure of the RSR SFDU.

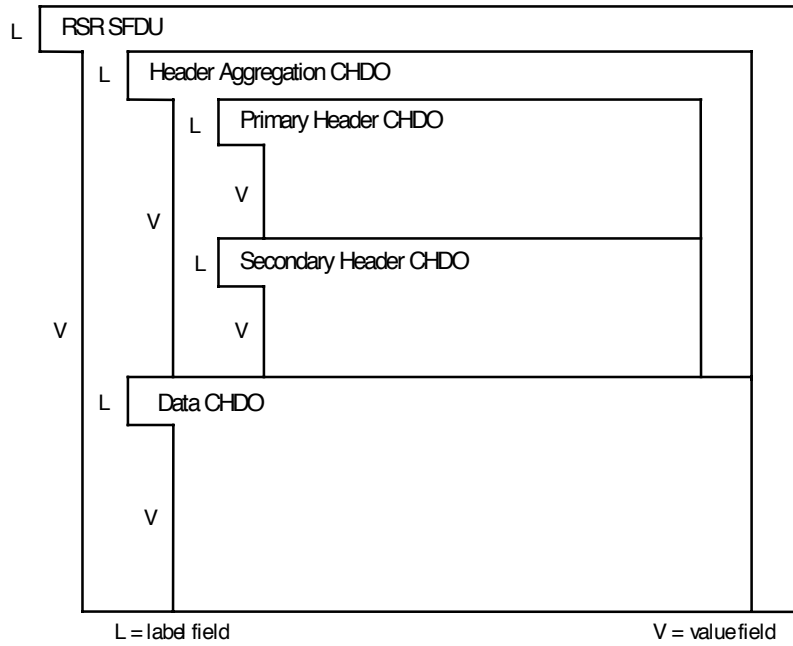

Figure 2-7. LVO Structure of the RSR SFDU

This page intentionally left blank

3 Detailed Interface Description

Section 3
Detailed Interface Description

3.1 RSR SFDU Physical Layout

The physical layout of the RSR SFDU is shown in figure 3-1. The structure is divided into five sections: the SFDU label, the header aggregation CHDO label, the primary header CHDO, the secondary header CHDO, and the data CHDO. The primary header CHDO and the secondary header CHDO together constitute the value field of the header aggregation CHDO; the header aggregation CHDO and the data CHDO together constitute the value field of the RSR SFDU.

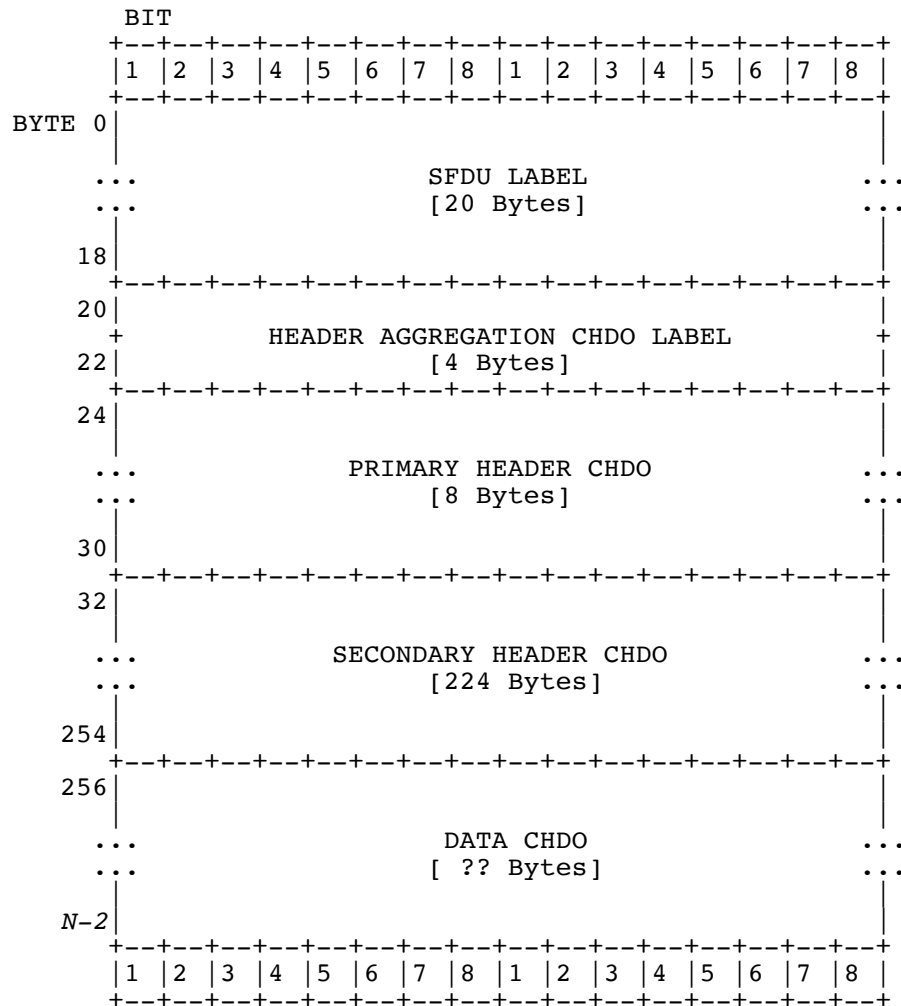

Figure 3-1. Physical Layout of the RSR SFDU

As shown in figure 3-1, the length of the RSR SFDU (in 8-bit bytes) is designated as N in this module. In general, the length of all items in the RSR SFDU are fixed, except for the data CHDO. The length of the data CHDO is variable and is determined by the sample rate and sample size of the recorded data. The length of the data CHDO is designated as M in this module. In any case, the total length of the RSR SFDU is easily ascertained from the length attribute in the SFDU label (total SFDU length $N = \text{SFDU length attribute} + 20$). Each section of the RSR SFDU is described in more detail in the following paragraphs.

3.2 RSR SFDU Label

Bytes 0 through 19 of the RSR SFDU in figure 3-1 contain the SFDU label field, which is illustrated in figure 3-2 and defined in the following paragraphs. The concatenation of bytes 0 to 3 and 8 to 11 constitutes the type attribute of the SFDU. In CCSDS parlance, that concatenated field is known as the Authority and Description Identifier (ADID). Bytes 12 through 19 constitute the length attribute of the SFDU.

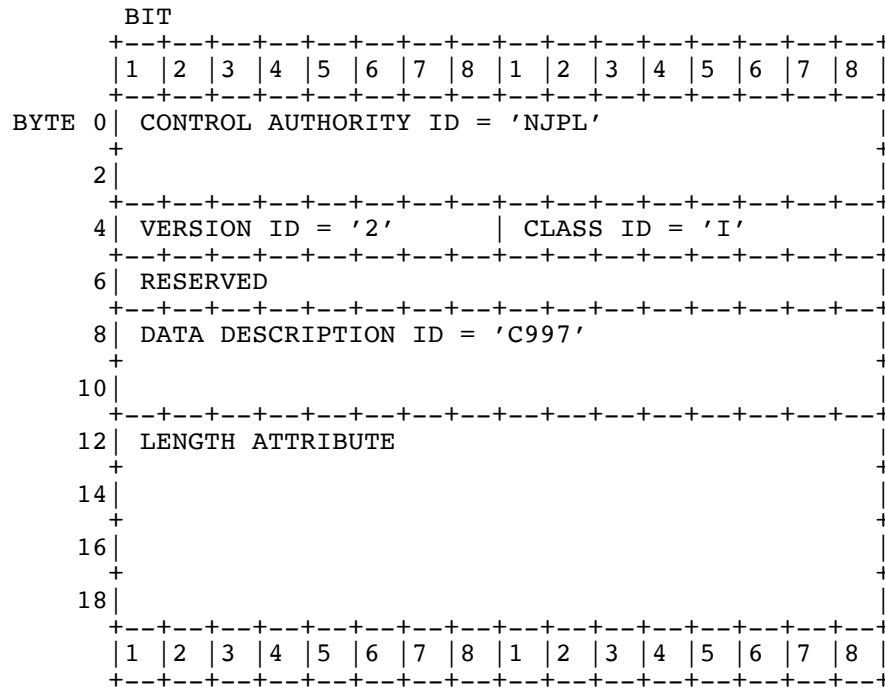

Figure 3-2. RSR SFDU Label

BYTES 0 TO 3

BITS

1 thru 8

Control authority identifier, value = 'NJPL', restricted ASCII. Indicates that the data description information for this type of SFDU is maintained and disseminated by the NASA/JPL control authority. Control authority identifiers are assigned by the CCSDS.

BYTE 4

BITS

1 thru 8

SFDU label version identifier, value = '2', restricted ASCII. Indicates that the length attribute field in bytes 12 to 19 of the SFDU label is formatted as a binary unsigned integer.

BYTE 5

BITS

1 thru 8 SFDU class identifier, value = 'I', restricted ASCII. Indicates that this is a CHDO structured SFDU.

BYTES 6 AND 7

BITS

1 thru 8 Reserved.

BYTES 8 TO 11

BITS

1 thru 8 Data description identifier, value = 'C997', restricted ASCII. Uniquely identifies the data description information maintained for this type of SFDU within the domain of the control authority identified in bytes 0 to 3. The value shown here is registered with the identified control authority (i.e., NJPL).

BYTES 12 TO 19

BITS

1 thru 8 Length attribute of the RSR SFDU, value varies but is always < 31K, binary unsigned integer. Indicates the length, in bytes, of the value field of the RSR SFDU, bytes 20 through *N-1* in figure 3-1. The length of the value field of the RSR SFDU is the sum of the total lengths of the header aggregation CHDO and the data CHDO.

3.3 Header Aggregation CHDO Label

Bytes 20 to 23 of the RSR SFDU in figure 3-1 contain the header aggregation CHDO label field, which is illustrated in figure 3-3 and defined in the following paragraphs. The value field of the header aggregation CHDO is composed of the primary header CHDO and the secondary header CHDO, which are defined in sections 3.4 and 3.5

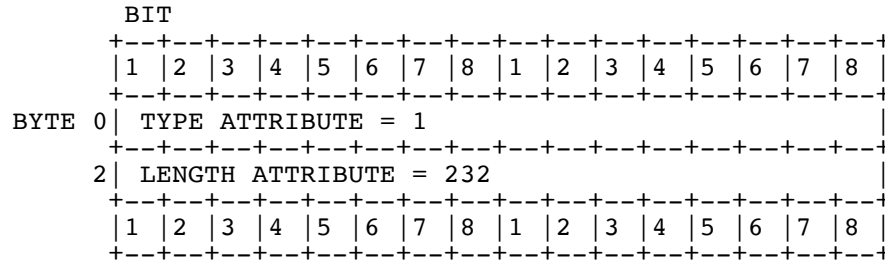

Figure 3-3. Header Aggregation CHDO Label

BYTES 0 AND 1

BITS

1 thru 8

Type attribute of the header aggregation CHDO, value = 1, binary unsigned integer. Indicates that this CHDO is an aggregation of header CHDOs. The NJPL control authority maintains a registry of CHDO type attributes.

BYTES 2 AND 3

BITS

1 thru 8

Length attribute of the header aggregation CHDO, value = 232, binary unsigned integer. Indicates the length, in bytes, of the value field of the header aggregation CHDO, bytes 24 through 255 in figure 3-1.

3.4 Primary Header CHDO

Bytes 24 through 31 of the RSR SFDU in figure 3-1 contain the primary header CHDO, which is illustrated in figure 3-4 and defined in the following paragraphs. Bytes 0 through 3 of the primary header CHDO are the label field; bytes 4 to 7 are the value field.

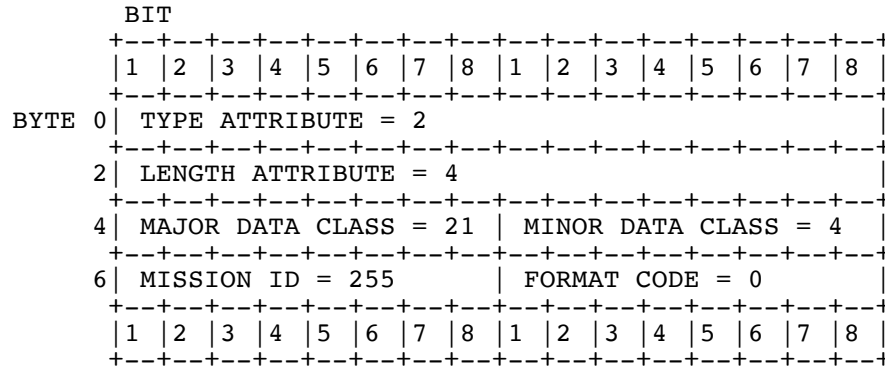

Figure 3-4. Primary Header CHDO

BYTES 0 AND 1

BITS

1 thru 8

Type attribute of the primary header CHDO, value = 2, binary unsigned integer. Indicates that this CHDO is a primary header CHDO. The NJPL control authority maintains a registry of CHDO type attributes.

BYTES 2 AND 3

BITS

1 thru 8

Length attribute of the primary header CHDO; value = 4, binary unsigned integer. Indicates the length, in bytes, of the value field of the primary header CHDO.

BYTE 4

BITS

1 thru 8

Major data class, value = 21, binary unsigned integer. Indicates that this SFDU contains radio science data.

BYTE 5

BITS

1 thru 8

Minor data class, value = 4, binary unsigned integer. Indicates that this SFDU was created by the RSR.

BYTE 6

BITS

1 thru 8 Mission identifier, value = 255, binary unsigned integer. Indicates that the RSR does not use this field. The mission identifier is added by the AMMOS GIF, the value is specified in 820-013, OPS-6-21A, Table 3-4.

BYTE 7

BITS

1 thru 8 Format code, value = 0, binary unsigned integer. The RSR only supports one data format which is discussed in section 3.6

3.5 Secondary Header CHDO

Bytes 32 through 255 of the RSR SFDU in figure 3-1 contain the secondary header CHDO, which is illustrated in figure 3-5 and defined in the following paragraphs. Bytes 0 to 3 of the secondary header CHDO are the label field; bytes 4 through 207 are the value field.

| BIT | | | | | | | | | | | | | | | |
|-----|-----------------------------------|---|---|---|---|---|---|-----------------------|---|---|---|---|---|---|---|
| 1 | 2 | 3 | 4 | 5 | 6 | 7 | 8 | 1 | 2 | 3 | 4 | 5 | 6 | 7 | 8 |
| 0 | TYPE ATTRIBUTE = 104 | | | | | | | | | | | | | | |
| 2 | LENGTH ATTRIBUTE = 220 | | | | | | | | | | | | | | |
| 4 | ORIGINATOR ID = 48 | | | | | | | LAST MODIFIER ID = 48 | | | | | | | |
| 6 | RSR SOFTWARE ID | | | | | | | | | | | | | | |
| 8 | RECORD SEQUENCE NUMBER | | | | | | | | | | | | | | |
| 10 | SPC ID | | | | | | | DSS ID | | | | | | | |
| 12 | RSR ID | | | | | | | SCHAN ID | | | | | | | |
| 14 | RESERVED | | | | | | | SPACECRAFT | | | | | | | |
| 16 | PRDX PASS NUMBER | | | | | | | | | | | | | | |
| 18 | U/L BAND (S,X,Ka) | | | | | | | D/L BAND (S,X,Ka) | | | | | | | |
| 20 | TRK MODE (1,2,3WAY) | | | | | | | U/L DSS ID | | | | | | | |
| 22 | FGAIN PX/NO | | | | | | | FGAIN IF BANDWIDTH | | | | | | | |
| 24 | FROV FLAG | | | | | | | ATTENUATION | | | | | | | |
| 26 | ADC RMS | | | | | | | ADC PEAK | | | | | | | |
| 28 | ADC INFO TIME TAG, YEAR | | | | | | | | | | | | | | |
| 30 | ADC INFO TIME TAG, DAY OF YEAR | | | | | | | | | | | | | | |
| 32 | ADC INFO TIME TAG, SECONDS OF DAY | | | | | | | | | | | | | | |
| 34 | | | | | | | | | | | | | | | |
| 36 | BITS PER SAMPLE | | | | | | | DATA ERROR | | | | | | | |
| 38 | SAMPLE RATE | | | | | | | | | | | | | | |
| 40 | DDC LO | | | | | | | | | | | | | | |
| 42 | RF->IF LO | | | | | | | | | | | | | | |
| 44 | SFDU TIME TAG, YEAR | | | | | | | | | | | | | | |
| 46 | SFDU TIME TAG, DAY OF YEAR | | | | | | | | | | | | | | |
| 48 | SFDU TIME TAG, SECONDS OF DAY | | | | | | | | | | | | | | |
| 50 | | | | | | | | | | | | | | | |
| 52 | | | | | | | | | | | | | | | |
| 54 | | | | | | | | | | | | | | | |
| 56 | PREDICTS TIME SHIFT | | | | | | | | | | | | | | |

| | |
|-----|----------------------------------|
| 58 | |
| 60 | |
| 62 | |
| 64 | PREDICTS FREQ OVERRIDE (FROV) |
| 66 | |
| 68 | |
| 70 | |
| 72 | PREDICTS FREQ RATE (FRR) |
| 74 | |
| 76 | |
| 78 | |
| 80 | PREDICTS FREQ OFFSET (FRR + FRO) |
| 82 | |
| 84 | |
| 86 | |
| 88 | SUB-CHANNEL FREQ OFFSET (SFRO) |
| 90 | |
| 92 | |
| 94 | |
| 96 | RF FREQ POINT 1 |
| 98 | |
| 100 | |
| 102 | |
| 104 | RF FREQ POINT 2 |
| 106 | |
| 108 | |
| 110 | |
| 112 | RF FREQ POINT 3 |
| 114 | |
| 116 | |
| 118 | |
| 120 | SCHAN FREQ POINT 1 |
| 122 | |
| 124 | |
| 126 | |
| 128 | SCHAN FREQ POINT 2 |

| | | | |
|-----|--|-------------------------|--|
| 130 | | | |
| 132 | | | |
| 134 | | | |
| 136 | | SCHAN FREQ POINT 3 | |
| 138 | | | |
| 140 | | | |
| 142 | | | |
| 144 | | SCHAN FREQ POLY COEF 1 | |
| 146 | | | |
| 148 | | | |
| 150 | | | |
| 152 | | SCHAN FREQ POLY COEF 2 | |
| 154 | | | |
| 156 | | | |
| 158 | | | |
| 160 | | SCHAN FREQ POLY COEF 3 | |
| 162 | | | |
| 164 | | | |
| 166 | | | |
| 168 | | SCHAN ACCUM PHASE | |
| 170 | | | |
| 172 | | | |
| 174 | | | |
| 176 | | SCHAN PHASE POLY COEF 1 | |
| 178 | | | |
| 180 | | | |
| 182 | | | |
| 184 | | SCHAN PHASE POLY COEF 2 | |
| 186 | | | |
| 188 | | | |
| 190 | | | |
| 192 | | SCHAN PHASE POLY COEF 3 | |
| 194 | | | |
| 196 | | | |
| 198 | | | |
| 200 | | SCHAN PHASE POLY COEF 4 | |



Figure 3-5. Secondary Header CHDO

BYTES 0 AND 1

BITS

1 thru 8

Type attribute of the secondary header CHDO; value = 104; unsigned binary integer. Indicates that this is an RSR secondary header CHDO. The NJPL control authority maintains a registry of CHDO type attributes.

BYTES 2 AND 3

BITS

1 thru 8

Length attribute of the secondary header CHDO; value = 220; unsigned binary integer. Indicates the length, in bytes, of the value field of the secondary header CHDO.

BYTE 4

BITS

1 thru 8

Originator identifier; value = 48; unsigned binary integer. Indicates that this SFDU originated within the DSN.

BYTE 5

BITS

1 thru 8

Last modifier identifier; value = 48; unsigned binary integer. Indicates that the contents of this SFDU were last modified by the DSN.

BYTE 6 AND 7

BITS

1 thru 8

RSR software identifier, value range 0 to $2^{16}-1$; unsigned binary integer. Identifies the RSR software version used to create this SFDU.

BYTES 8 AND 9
BITS

1 thru 8 Record sequence number (RSN); value range 0 to $2^{16}-1$; unsigned binary integer. The RSN is a sequence counter for the RSR SFDUs. It starts at zero and increments by one for each successive RSR SFDU in a stream. It wraps around from $2^{16}-1$ to zero. The RSN may reset to zero at any time (e.g., whenever the RSR is started or restarted); however, such resets should be infrequent. The RSN is provided by the originator of the RSR SFDU and shall not be changed subsequently; e.g., a RSR SFDU replayed from a recording shall retain the RSN that was assigned when the SFDU was created.

BYTE 10
BITS

1 thru 8 Signal Processing Center (SPC) identifier; valid values are 10, 40, 60, and 21; unsigned binary integer. Indicates the SPC at which the SFDU was created, 10 => Goldstone, 40 => Canberra, 60 => Madrid, 21 => DTF21.

BYTE 11
BITS

1 thru 8 Deep Space Station (DSS) identifier; value range 0 to 2^8-1 ; unsigned binary integer. Specifies the DSS identifier listed in the frequency predicts file used to collect the radio science data in this SFDU. For example a value of 15 indicates DSS-15. DSS identifiers are defined in 820-013, OPS-6-3.

BYTE 12
BITS

1 thru 8 Radio Science Receiver (RSR) identifier; value range 1 to 16; unsigned binary integer. Specifies the RSR used to acquire the radio science data in this SFDU, 1 => RSR1A, 2 => RSR1B, 3 => RSR2A, 4 => RSR2B, etc.

BYTE 13
BITS

1 thru 8 Sub-channel identifier; value range 1 to 4; unsigned binary integer. Specifies the RSR sub-channel used to acquire the radio science data in this SFDU.

BYTE 14
BITS

1 thru 8 Reserved.

BYTE 15
BITS

1 thru 8 DSMS-assigned spacecraft identifier; value range 0 to 2^8-1 ; unsigned binary integer. Specifies the spacecraft identifier listed in the frequency predicts file used to collect the radio science data in this SFDU. See 820-013, OPS-6-21A, Table 3-4.

BYTES 16 AND 17

BITS

1 thru 8 Predicts Pass Number; value range 0 to $2^{16}-1$; unsigned binary integer. Specifies the DSN pass number listed in the predicts file used to collect the radio science data in this SFDU.

BYTE 18

BITS

1 thru 8 Uplink frequency band; valid values are S, X, and K; restricted ASCII. Specifies the uplink frequency band listed in the predicts file used to collect the radio science data in this SFDU, S => S-band, X => X-band, K => Ka-band.

BYTE 19

BITS

1 thru 8 Downlink frequency band; valid values are S, X, and K; restricted ASCII. Specifies the downlink frequency band listed in the predicts file used to collect the radio science data in this SFDU, S => S-band, X => X-band, K => Ka-band.

BYTE 20

BITS

1 thru 8 Tracking mode; value range 1 to 3; unsigned binary integer. Specifies the tracking mode in use by the RSR at the time the radio science data in this SFDU was acquired, 1 => one-way, 2 => two-way, 3 => three-way. Refer to the WAY command in the SOM for more information.

BYTE 21

BITS

1 thru 8 Uplink DSS identifier for tracking mode = three-way; value range 0-255; unsigned binary integer, as specified in 820-013, OPS-6-3. Specifies the uplink DSS identifier portion of the tracking mode when the RSR is configured for three way tracking.

BYTE 22

BITS

1 thru 8 FGAIN Px/No in dB-Hz; value range -128 to $+127$; signed binary integer. Specifies the value of the expected Px/No in use by the RSR at the time the radio science data in this SFDU was acquired. This parameter is used to compute the settings of the sub-channel filter gain. Refer to the FGAIN command in the SOM for more information.

BYTE 23

BITS

1 thru 8 FGAIN IF Bandwidth in Mega-Hz; value range 1 to 127; unsigned binary integer. Specifies the value of the expected IF bandwidth in use by the RSR at

the time the radio science data in this SFDU was acquired. This parameter is used to compute the settings of the sub-channel filter gain. Refer to the FGAIN command in the SOM for more information.

BYTE 24

BITS

1 thru 8 Frequency predicts override flag; range 255; unsigned binary integer. A value of 0 indicates that the frequency predicts file is in use, any other value indicates that the frequency specified by the FROV command is in use. The value of the override frequency is specified in bytes 64-71

BYTE 25

BITS

1 thru 8 DIG attenuation; value range 0-63; unsigned binary integer. Specifies the current setting of the DIG attenuator in 0.5 dB increments. Refer to the ATT command in the SOM for more information.

BYTE 26

BITS

1 thru 8 DIG ADC RMS amplitude; value range 0-128; unsigned binary integer. Indicates the RMS amplitude of the 8-bit sample stream produced by the DIG ADC. A time-tag for the measurement is provided in bytes 28-35

BYTE 27

BITS

1 thru 8 DIG ADC peak amplitude; value range 0-128; unsigned binary integer. Indicates the peak amplitude of the 8-bit sample stream produced by the DIG ADC. A time-tag for the measurement is provided in bytes 28-35

BYTES 28 AND 29

BITS

1 thru 8 ADC info time tag - year; value range 1900 to 3000; unsigned binary integer. Specifies the UTC year of the ADC info.

BYTES 30 AND 31

BITS

1 thru 8 ADC info time tag – day of year; value range 1 to 366; unsigned binary integer. Specifies the UTC day of year of the ADC info.

BYTES 32 TO 35

BITS

1 thru 8 ADC info time tag – seconds of day; value range 0 to 86400; unsigned binary integer. Specifies the UTC second of day of the ADC info.

BYTE 36

BITS

1 thru 8 Sample resolution in bits per data sample; valid values are 1, 2, 4, 8, and 16; unsigned binary integer. Specifies the size of the data samples contained in this SFDU. Sample resolution is specified by the operator while the RSR is in the configure state. Refer to the SOM for more information.

BYTE 37

BITS

1 thru 8 Data error count; value range 0 to 255; unsigned binary integer. Specifies the number of hardware errors encountered while the data contained in this SFDU was being recorded. A value greater than 0 indicates data may be corrupted due to hardware errors.

BYTES 38 AND 39

BITS

1 thru 8 Sample rate in Kilo-samples per second ; valid values are listed in table 3-1; unsigned binary integer. Specifies the sample rate of the data contained in this SFDU. Sample rate or bandwidth is specified by the operator while the RSR is in the configure state. Refer to the SOM for more information.

BYTE 40 AND 41

BITS

1 thru 8 Digital Down Converter LO (DDC LO) in Mega-Hz; value range 265 to 375; unsigned binary integer. Specifies the total down conversion applied to the signal in the DIG and DDC. This frequency is needed in order to compute the sky frequency of the data contained in this SFDU. Refer to the DDCLO command in the SOM for more information.

BYTE 42 AND 43

BITS

1 thru 8 RF to IF down converter LO in Mega-Hz; value range 0 to $2^{16}-1$; unsigned binary integer. Specifies the total down conversion applied to the signal before it entered the RSR DIG. This value is subtracted from the RF predicts points in order to obtain the frequency of the desired signal at IF. This frequency is needed in order to compute the sky frequency of the data contained in this SFDU. The RSR selects a default value based on the downlink frequency band, S-band => 2000, X-band => 8100, Ka-band =>31700.

BYTES 44 AND 45

BITS

1 thru 8 SFDU time tag - year; value range 1900 to 3000; unsigned binary integer. Specifies the UTC year of the SFDU data and models. More information on time tags is provided in section 2.5

BYTES 46 AND 47

BITS

1 thru 8

SFDU time tag – day of year; value range 1 to 366; unsigned binary integer
Specifies the UTC day of year of the SFDU data and models.

BYTES 48 TO 55

BITS

1 thru 8

SFDU time tag – seconds of day; value range 0.0 to 86400.0; double precision
floating point. Specifies the UTC second of day of the SFDU data and models.

BYTES 56 TO 63

BITS

1 thru 8

Predicts time shift in seconds; double precision floating point. Indicates the
number a seconds added to the time tags of the frequency predicts points in order
to shift them in time. This is a feature of the RSR that is provided to allow
testing the system with old predicts files. Should have a value of 0.0 in all
SFDUs recorded during a standard pass.

BYTES 64 TO 71

BITS

1 thru 8

Predicts frequency override in Hz; double precision floating point. Indicates the
value of the predicts frequency override as specified by the FROV command.
Byte 24 contains a flag which indicates if the frequency override is active.

BYTES 72 TO 79

BITS

1 thru 8

Predicts frequency rate in Hz per second; value range –8 to +8 Kilo-Hz per
second; double precision floating point. Indicates the frequency rate added to
the RF frequency predicts as specified by the FRR command.

BYTES 80 TO 87

BITS

1 thru 8

Predicts frequency offset in Hz; value range –8 to +8 Mega-Hz; double precision
floating point. Indicates the total frequency added to the RF frequency predicts
as specified by the FRO command and the accumulation of the frequency rate as
specified by the FRR command .

BYTES 88 TO 95

BITS

1 thru 8

Sub-channel frequency offset in Hz; value range –8 to +8 Mega-Hz; double
precision floating point. Indicates the value of the frequency offset added to the
frequency predicts for this sub-channel as specified by the SFRO command.

BYTES 96 TO 119

BITS

1 thru 8

RF frequency points; double precision floating point, The values of the RF frequency points as calculated from the frequency predicts for the beginning, middle, and end of the second.

BYTES 120 TO 143

BITS

1 thru 8

Sub-channel frequency points; double precision floating point. The values of the sub-channel frequency points for the beginning, middle, and end of the second. These are the frequency points used to create the sub-channel phase and frequency polynomials.

BYTES 144 TO 167

BITS

1 thru 8

Sub-channel frequency polynomial coefficients; double precision floating point. The values of the sub-channel frequency polynomial coefficients as calculated from the sub-channel frequency points. Refer the section 2.4 for more information.

BYTES 168 TO 175

BITS

1 thru 8

Sub-channel accumulated phase; double precision floating point. The value of the accumulated whole turns of the sub-channel phase polynomial. Refer the section 2.4 for more information.

BYTES 176 TO 207

BITS

1 thru 8

Sub-channel phase polynomial coefficients; double precision floating point. The values of the sub-channel phase polynomial coefficients as calculated from the sub-channel frequency polynomial coefficients. Refer the section 2.4 for more information.

BYTES 208 TO 223

BITS

1 thru 8

Reserved.

3.6 Data CHDO

Bytes 256 through $N-1$ of the RSR SFDU in figure 3-1 contain the data CHDO, which is illustrated in figure 3-6 and is defined in the following paragraphs. Bytes 0 to 3 of the data CHDO are the label field; Bytes 4 through $M-1$ are the value field.

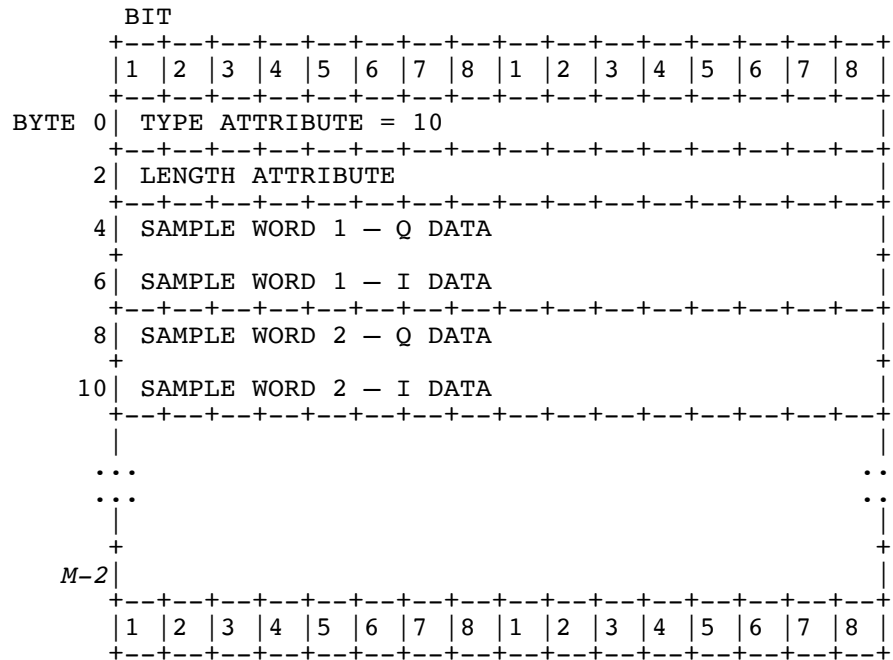

Figure 3-6. RSR Data CHDO

BYTES 0 AND 1

BITS

1 thru 8

Type attribute of the data CHDO; value = 10; unsigned binary integer. Indicates that this CHDO contains binary data.

BYTES 2 AND 3

BITS

1 thru 8

Length attribute of the data CHDO in bytes; value range 0 to $2^{16}-1$; unsigned binary integer. Indicates the length of the value field of the data CHDO. The length is determined by the sample rate and sample size of the recorded data as specified in Table 3-1.

Table 3-1. Supported Sample Rates and Samples Sizes

| Category | Sample Rate (Ksamp/sec) | Sample Size (bits/samp) | Data rate (bytes/sec) | Data rate (SFDUs/sec) | Data Length (bytes) | |
|-------------------------|-------------------------|-------------------------|-----------------------|-----------------------|---------------------|--|
| NB – narrow band | 1 | 8 | 2,000 | 1 | 2,000 | |
| | 2 | 8 | 4,000 | 1 | 4,000 | |
| | 4 | 8 | 8,000 | 1 | 8,000 | |
| | 8 | 8 | 16,000 | 1 | 16,000 | |
| | 16 | 8 | 32,000 | 2 | 16,000 | |
| | 25 | 8 | 50,000 | 2 | 25,000 | |
| | 50 | 8 | 100,000 | 4 | 25,000 | |
| | 100 | 8 | 200,000 | 10 | 20,000 | |
| | | | | | | |
| | 1 | 16 | 4,000 | 1 | 4,000 | |
| | 2 | 16 | 8,000 | 1 | 8,000 | |
| | 4 | 16 | 16,000 | 1 | 16,000 | |
| | 8 | 16 | 32,000 | 2 | 16,000 | |
| | 16 | 16 | 64,000 | 4 | 16,000 | |
| | 25 | 16 | 100,000 | 4 | 25,000 | |
| | 50 | 16 | 200,000 | 10 | 20,000 | |
| | 100 | 16 | 400,000 | 20 | 20,000 | |
| | | | | | | |
| MB – medium band | 250 | 1 | 62,500 | 5 | 12,500 | |
| | 500 | 1 | 125,000 | 5 | 25,000 | |
| | 1,000 | 1 | 250,000 | 10 | 25,000 | |
| | 2,000 | 1 | 500,000 | 20 | 25,000 | |
| | 4,000 | 1 | 1,000,000 | 40 | 25,000 | |
| | | | | | | |
| | 250 | 2 | 125,000 | 5 | 25,000 | |
| | 500 | 2 | 250,000 | 10 | 25,000 | |
| | 1,000 | 2 | 500,000 | 20 | 25,000 | |
| | 2,000 | 2 | 1,000,000 | 40 | 25,000 | |
| | 4,000 | 2 | 2,000,000 | 100 | 20,000 | |
| | | | | | | |
| | 250 | 4 | 250,000 | 10 | 25,000 | |
| | 500 | 4 | 500,000 | 20 | 25,000 | |
| | 1,000 | 4 | 1,000,000 | 40 | 25,000 | |
| | 2,000 | 4 | 2,000,000 | 100 | 20,000 | |
| | | | | | | |
| 250 | 8 | 500,000 | 20 | 25,000 | | |
| 500 | 8 | 1,000,000 | 40 | 25,000 | | |
| 1,000 | 8 | 2,000,000 | 100 | 20,000 | | |
| | | | | | | |
| WB – wide band | 8,000 | 1 | 2,000,000 | 100 | 20,000 | |
| | 16,000 | 1 | 4,000,000 | 200 | 20,000 | |
| | | | | | | |
| | 8,000 | 2 | 4,000,000 | 200 | 20,000 | |

Category The supported data rates and resolutions are split into three different categories based of the number of sub-channels that can be supported. In NB, up to 4 sub-

channels can be recorded simultaneously; in MB, at most 2 sub-channels; and in WB, only 1 sub-channel can be recorded.

| | |
|-------------|--|
| Sample Rate | The supported sample rate in Kilo-samples / sec. |
| Sample Size | The number of bits of resolution in each of the In-phase (I) and Quadrature-phase (Q) samples. |
| Data Rate 1 | The number of bytes per second coming from a subchannel. |
| Data Rate 2 | The number of SFDUs per second coming from a subchannel. |
| Data Length | The number of data bytes in the value field of each data CHDO coming from a subchannel. |

BYTES 4 THRU (M-1)

BITS

1 thru 8 RSR data samples; The RSR digitally samples the received spacecraft signal with between 1-bit and 16-bit resolution. The samples are packed into 32-bit words. The most significant 16 bits always contain quadrature-phase (Q) data and the least significant 16 bits always contain in-phase (I) data. Between 1 to 16 samples are packed into each 32-bit word depending on how many bits per sample are used. The time order of the packed bits is from LSB to MSB. Table 3-2 specifies the bit packing for the various sample resolutions.

The RSR uses truncation to reduce the number of bits per sample to the desired value. This truncation creates an offset of -0.5 in the output data stream which must be corrected in post processing software. To compensate for this offset each RSR data sample should be put through the transformation $2^k + 1$ where k is the 2's complement value of the 1, 2, 4, 8 or 16 bit sample. Note that the value zero is not present in this data representation. However, all bits are used and the data is symmetric about zero.

Table 3-2. Sample Packing

| Bits Per Sample | Contents of 32 Bit Packed Data Register |
|------------------------|--|
| 16 Bits | [Q1],[I1] |
| 8 Bits | [Q2,Q1] , [I2, I1] |
| 4 Bits | [Q4, Q3, Q2, Q1], [I4, I3, I2, I1] |
| 2 Bits | [Q8, Q7,... Q2, Q1], [I8, I7,... I2, I1] |
| 1 Bit | [Q16, Q15,... Q2, Q1], [I16, I15,... I2, I1] |

Appendix A

A.1 Abbreviations

Abbreviations and acronyms used in this document are defined where they first occur in the text. A complete list is provided here for the convenience of the reader. Abbreviations and acronyms approved for use are listed in Document 820-062.

| | |
|-------|--|
| ADC | Analog to Digital Conversion |
| AMMOS | Advanced Multi-Mission Operations System |
| ANSI | American National Standards Institute |
| ASCII | American Standard Code for Information Interchange |
| ASD | Application Specific Digital Signal Processing Board |
| BSN | Block Serial Number |
| BPF | Band Pass Filter |
| CCSDS | Consultative Committee for Space Data Systems |
| CDE | Cognizant Development Engineer |
| CDR | Central Data Recorder |
| CHDO | Compressed Header Data Object |
| DDC | Digital Down Converter subassembly |
| DDD | DSN Data Delivery |
| DDS | Distributed Data Service (proprietary to FSP) |
| DIG | Digitizer subassembly |
| DLT | Digital Linear Tape |
| DP | RSR Data Processor |
| DSCC | Deep Space Communications Complex |
| DSMS | Deep Space Mission System |
| DSN | Deep Space Network |
| DSP | Digital Signal Processing |
| DSS | Deep Space Station |
| DTF | Development and Test Facility |
| DTS | Data Transport Subsystem |
| FFT | Fast Fourier Transform |
| FIR | Finite Impulse Response filter |
| FRO | Frequency Offset |
| FROV | Frequency Override |
| FRR | Frequency Rate |
| FSP | Full Spectrum Processing subsystem |
| FTDD | Fault Tolerant Data Delivery |
| FTP | File Transfer Protocol |
| FTS | Frequency and Timing Subsystem |
| GCF | Ground Communications Facility |
| GCS | Ground Communications System |
| GIF | GCF Interface |
| I, Q | In-phase and Quad-phase samples |
| ID | Identifier |
| IF | Intermediate Frequency |
| IFS | IF Switch |
| IP | Internet Protocol |
| ISO | International Organization for Standardization |
| JPL | Jet Propulsion Laboratory |

| | |
|------------|---|
| LO | Local Oscillator |
| LPF | Low Pass Filter |
| LSB | Least Significant Bit |
| LVO | Label Value Object |
| MGDS | Multi-Mission Ground Data System |
| MSB | Most Significant Bit |
| N0 | Noise power in 1 Hz. |
| NASA | National Aeronautics and Space Administration |
| NB, MB, WB | Narrow-band, Medium-band, Wide-band |
| NCO | Numerically Controlled Oscillator |
| NJPL | NASA/Jet Propulsion Laboratory (control authority identifier) |
| NOPE | Network Operations Project Engineer |
| PCNO | Carrier power relative to noise power in a 1Hz bandwidth |
| 1PPS | 1 Pulse Per Second |
| RA | Restricted ASCII |
| RF | Radio frequency |
| RNS | Reliable Network Server |
| RSN | Record Sequence Number |
| RSR | Radio Science Receiver |
| RT | Real Time processor |
| SDB | Standard DSN Block |
| SFDU | Standard Formatted Data Unit |
| SNR | Signal-to-Noise Ratio |
| TCP | Transmission Control Protocol |
| TDS | Telemetry Delivery Subsystem |
| TMOD | Telecommunications and Mission Operations Directorate |
| UTC | Coordinated Universal Time |
| VDP | VME Data Processor |
| VME | VersaModule Eurocard |